



## Gas sensor GSE 307 for detection of Hydrogen H<sub>2</sub>



### Mode of operation

The principle of the measurement cell used is based on the electro-chemical oxidation of hydrogen H<sub>2</sub> on the working electrode. The H<sub>2</sub> in the measurement air reaches the working electrode via a gas-permeable diaphragm, and is oxidised. The oxygen molecule used for this is replaced from the ambient air. This results in the very long service life of the measurement cell, which, from experience, can operate for several years.

The measured gas concentration is linear to the electrical output signal of the gas measurement probe. The potentiometers and the 3.5 mm jack connection for the calibration are accessible from the outside, and permits a "one-man" calibration.

When used in a pump system, the service life can be heavily reduced, as the electrolyte evaporates more quickly through the porous diaphragm. The measurement cell is sensitive to solvent vapours.

The **calibration gas** should be 75% of the measurement range, and must contain synthetic air as the carrier gas.

## Performance Characteristics

Sensitivity:	10 ppm
Measuring range:	max. 40'000 ppm / linear
Standard calibration:	0...10'000 ppm/ 0...4 Vol. %
Response time $t_{90}$ :	$\leq 110$ sec
Operating temperature:	-20 °C ... +50 °C
Start up after reconditioning:	max. 1 h
Pressure range:	atmospheric $\pm 10\%$
Air humidity:	15...90% non condensing
Position sensitivity:	none
Long term output drift:	< 2% / month
Life span at 20 °C:	at least 2 years depends on the application

## Cross sensitivity to other gases

Test gas	concentration of the test gas	display on the CO-Sensor
Chlorine Cl <sub>2</sub>	1 ppm	0 ppm
Hydrogen Chloride HCl	5 ppm	0 ppm
Hydrogen Cyanide HCN	10 ppm	~ 10 ppm
Ethylene C <sub>2</sub> H <sub>4</sub>	100 ppm	~ 40 ppm
Carbon Monoxide CO	300 ppm	< 120 ppm
Sulphur Dioxide SO <sub>2</sub>	5 ppm	0 ppm
Hydrogen Sulphide H <sub>2</sub> S	15 ppm	~ 10 ppm
Nitric Dioxide NO <sub>2</sub>	5 ppm	0 ppm
Nitric Oxide NO	35 ppm	< 10 ppm
Hydrogen H <sub>2</sub>	20'000 ppm	20'000 ppm

## Sensor electronic specification

Cable:	2-core cable, shielded
Power supply:	13.5...30 VDC
Sensor current:	max. 60 mA
Output signal:	4...20 mA/ max. 60 mA
Operating temperature:	-40 °C ... +85 °C

## Inspection (Maintenance)

The sensor and the electronic require an inspection.  
Routine calibration is recommended once or twice a year.

## Electronic

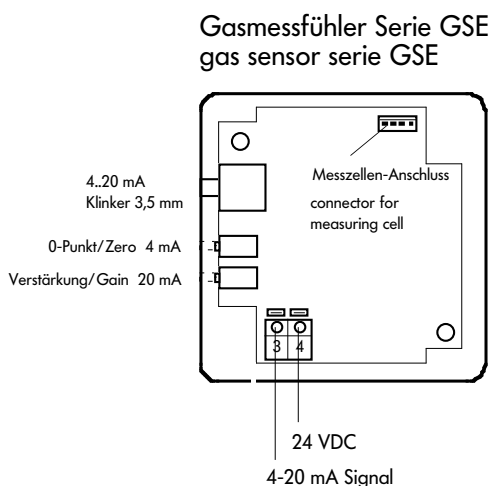

## Dimensions

