



Gas sensor GSE 401 for detection of Oxygen O₂



Mode of operation

The principle of the measurement cell used is based on the diffusion of oxygen. The O₂ diffuses through the gas-permeable diaphragm onto the gold cathode, and is reduced on it. The current flowing between the electrodes is proportional to the concentration, and will then be amplified and be led to the evaluation device by the transmitter.

The measured gas concentration is linear to the electrical output signal of the gas measurement probe. The potentiometers and the 3.5 mm jack connection for the calibration are accessible from the outside, and permits a "one-man" calibration.

When used in a pump system, the service life can be heavily reduced, as the electrolyte evaporates more quickly through the porous diaphragm. The measurement cell is sensitive to solvent vapours.

The **calibration gas** should be 75% of the measurement range, and must contain synthetic air as the carrier gas.

Performance Characteristics

Sensitivity:	at least 0,5 Vol.%
Measuring range:	max. 25 Vol.% / linear
Response time t_{95} :	< 10 seconds
Operating temperature:	-20 °C ... +45°C
Start up after reconditioning:	max. 1 h
Pressure range:	atmospheric \pm 10%
Air humidity:	0...99% non condensing
Position sensitivity:	none
Long term output drift:	< 5 % / year
Life span at 20 °C:	at least 1 year/ max 2 years depends on the application
Warranty period:	6 months

Cross sensitivity to other gases

Test gas	concentration of the test gas	display on the O_2 -Sensor
Ammonia NH_3	100 ppm	0 ppm
Chlorine Cl_2	... ppm	... ppm
Ethylene C_2H_4	... ppm	... ppm
Carbon Dioxide CO_2	5'000 ppm	0 ppm
Carbon Monoxide CO	250 ppm	0 ppm
Propane C_3H_8	5'000 ppm	0 ppm
Sulphur Dioxide SO_2	... ppm	... ppm
Hydrogen Sulphide H_2S	100 ppm	< 1 ppm
Nitrogen Dioxide NO_2	20 ppm	< 1 ppm
Nitric Oxide NO	48 ppm	< 1 ppm
Hydrogen H_2	100 ppm	0 ppm

Sensor electronic specification

Cable:	2-core cable, shielded
Power supply:	13.5...30 VDC
Sensor current:	max. 60 mA
Output signal:	4...20 mA/max. 60 mA
Operating temperature:	-40 °C ... +85 °C

Inspection (Maintenance)

The sensor and the electronic require an inspection. Routine calibration is recommended once or twice a year.

Electronic

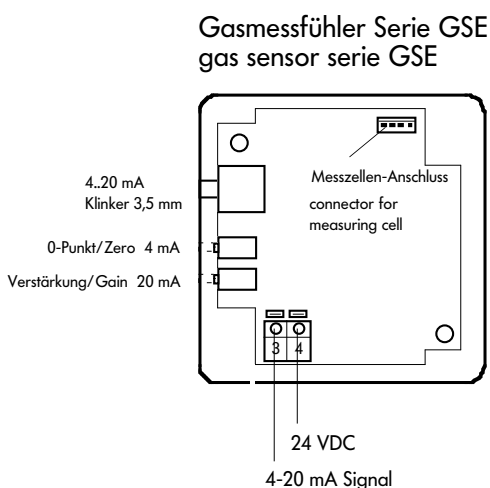

Dimensions

