

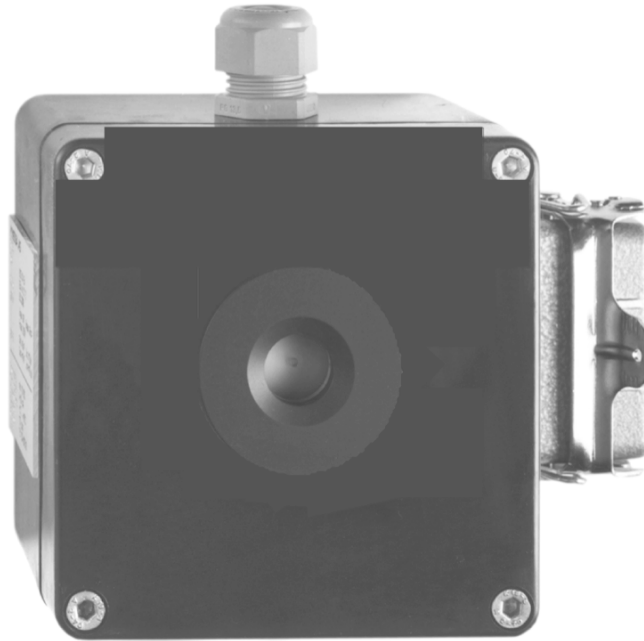

Gas sensor GSE 507 Ex for detection of Carbon Monoxide CO



Mode of operation

The principle of the measurement cell used is based on the electro-chemical oxidation of carbon monoxide CO to carbon dioxide CO₂. The CO in the measurement air reaches the working electrode via a gas-permeable diaphragm, and is oxidised. The oxygen molecule used for this is replaced from the ambient air. This results in the very long service life of the measurement cell, which, from experience, can operate for several years.

The measured gas concentration is linear to the electrical output signal of the gas measurement probe. The potentiometers and the 3.5 mm jack connection for the calibration are accessible from the outside, and permits a "one-man" calibration.

When used in a pump system, the service life can be heavily reduced, as the electrolyte evaporates more quickly through the porous diaphragm. The measurement cell is sensitive to solvent vapours.

The **calibration gas** should be 75% of the measurement range, and must contain synthetic air as the carrier gas.

Performance Characteristics

Sensitivity:	at least 1 ppm
Measuring range:	max. 1000 ppm / linear
Standard calibration:	0...100 / 0...250 ppm
Response time t_{90} :	≤ 30 sec
Operating temperature:	-20 °C ... +50 °C
Start up after reconditioning:	max. 1 h
Pressure range:	atmospheric $\pm 10\%$
Air humidity:	15...90% non condensing
Position sensitivity:	none
Long term output drift:	$< 5\%$ / year
Life span at 20 °C:	at least 3 years depends on the application

Sensor electronic specification

Cable:	2-core cable, shielded
Power supply:	13.5...30 VDC
Sensor current:	max. 60 mA
Output signal:	4...20 mA / max. 60 mA
Operating temperature:	-40 °C ... +85 °C

Inspection (Maintenance)

The sensor and the electronic require an inspection. Routine calibration is recommended once or twice a year.

Dimensions

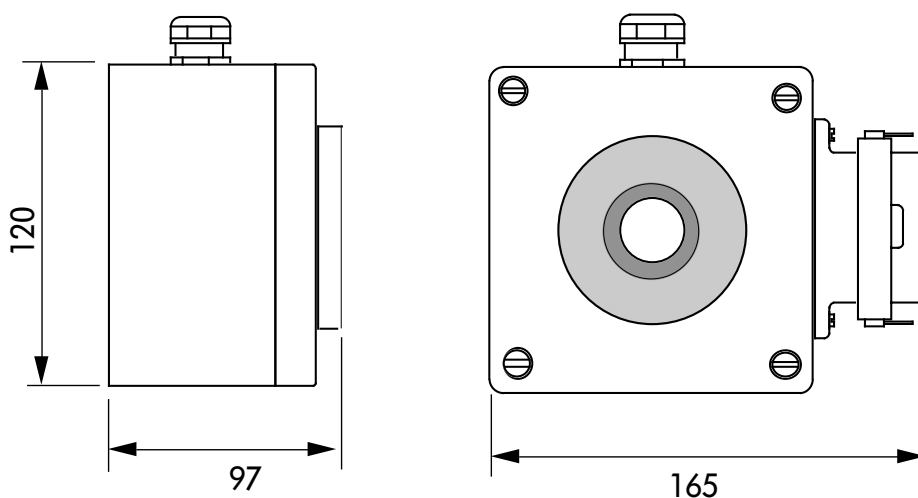

cover cap for:
 - calibration potentiometer
 - output signal connection
 (3,5 mm jack)

Cross sensitivity to other gases

<u>Test gas</u>	<u>concentration of the test gas</u>	<u>display on the CO-Sensor</u>
Chlorine Cl ₂	1 ppm	0 ppm
Hydrogen Chloride HCl	5 ppm	0 ppm
Hydrogen Cyanide HCN	10 ppm	< 2 ppm
Ethylene C ₂ H ₄	100 ppm	≤ 100 ppm
Ethanol C ₂ H ₅ OH	200 ppm	0 ppm
Carbon Monoxide CO	250 ppm	250 ppm
Sulphur Dioxide SO ₂	5 ppm	0 ppm
Hydrogen Sulphide H ₂ S	15 ppm	< 0.3 ppm
Nitric Oxide NO	35 ppm	≤ 7 ppm
Hydrogen H ₂	100 ppm	< 60 ppm

Explosion-proof construction

( II 2G Ex ia IIC T4)

Certificate of conformity BVS 09 ATEX E 101 X

The gas measurement probe of the series GSE ... Ex must be operated with a Zener barrier. The supply must be designed to be "intrinsically safe" and the colour must be blue.